

CXP 45/2 MAX

Gas burners two stages with: aluminum body, fan at high pressurization at reverse blades and combustion head with adjustment at high efficiency and high flame stability.

Compact overall dimensions and disposition rationalized of the components with accessibility facilitated for the operations of setting and maintenance.

Available in the versions METHANE (natural gas) or L.P.G. (to specify at the order) on demand specific versions for town gas, coal gas or biogas.

Gas train completely assembled, electrically linked and tested; complete of two stages working valve with flow adjustment, safety valve, minimum gas pressure switch and stabilizer filter of gas pressure.

Complete of flange and gasket for installation on generator.

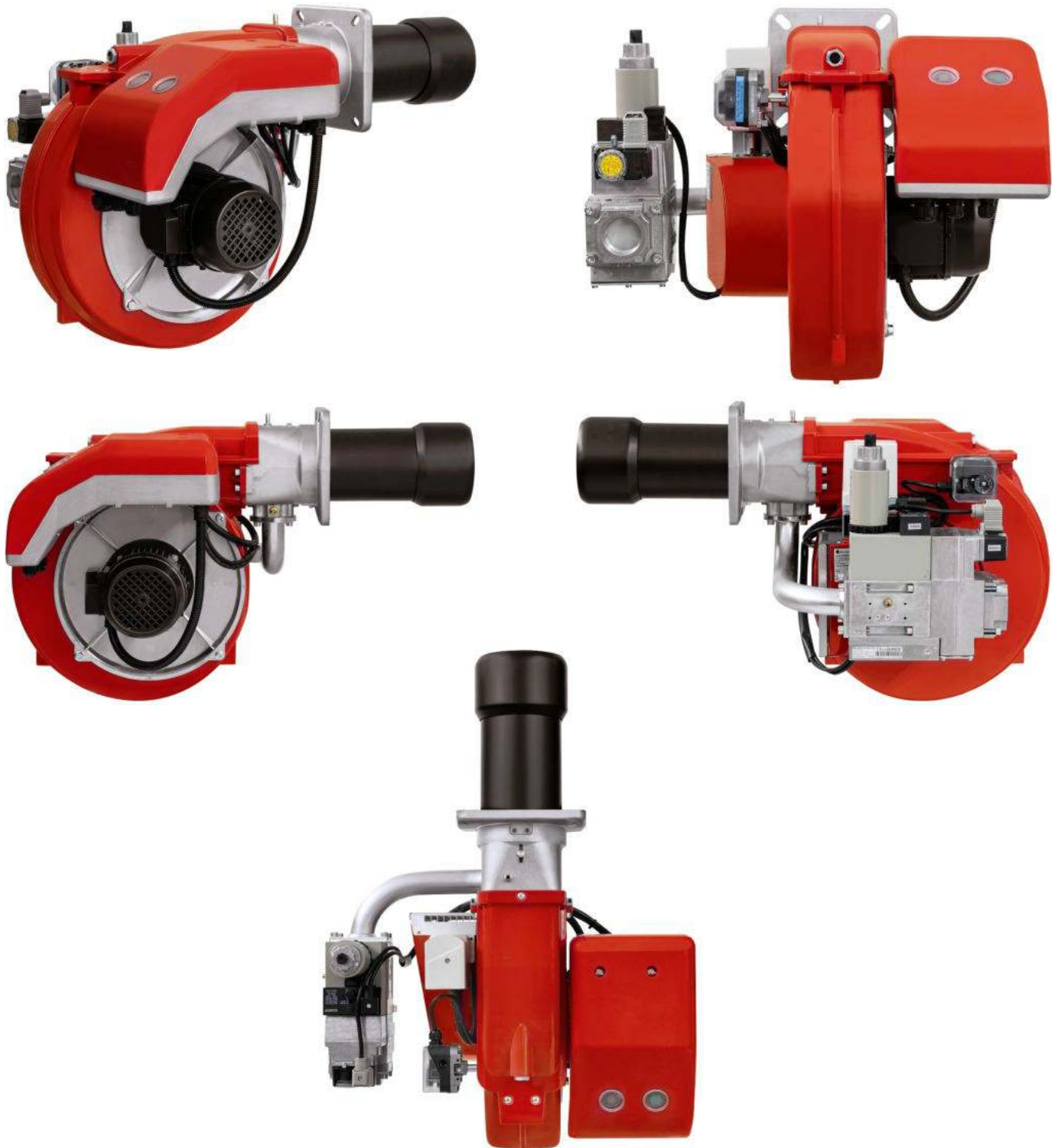

Fig. 1 CXP-45/2 MAX

TECHNICAL DATA AND OPERATING RANGE DIAGRAM CXP-45/2 MAX

MODEL	CXP-45/2 MAX	
Thermal power min. 1°st. / min. 2°st. - max. 2°st. *	[Mcal/h]	100/200-542
Thermal power min. 1°st. / min. 2°st. - max. 2°st. *	[kW]	116/232-630
Gas flow G20 (NATURAL GAS) min. 1°st. / min. 2°st. - max. 2°st. *	[Nm³/h]	11.6/23.3-63.3
Gas flow G31 (L.P.G.) min. 1°st. / min. 2°st. - max. 2°st. *	[Nm³/h]	4.5/9-24.5
Fuel: NATURAL GAS (second family) - L.P.G. (third family)		
Fuel category:	I2R,I2H,I2L,I2E,I2E+,I2Er,I2ELL,I2E(R) I3B/P,I3+,I3P,I3B,I3R	
Intermittent working operation (min. 1 stop every 24 hours) two stages		
Environmental conditions operation / storage:	-15...+40°C / -20...+70°C, humidity rel. max. 80%	
Max. temperature combustion air	[°C]	60
Minimum pressure gas train D1"-S NATURAL GAS/L.P.G. **	[mbar]	115.3 / 60
Minimum pressure gas train D1"1/4-S NATURAL GAS/L.P.G. **	[mbar]	54.5 / 37.4
Minimum pressure gas train D1"1/2-S NATURAL GAS/L.P.G. **	[mbar]	17.7 / 21.8
Maximum pressure at the entry of valves (Pe. max)	[mbar]	360
Nominal electric power	[W]	700
Fan motor	[W]	550
Nominal motor current absorption	[A]	1.4
Nominal auxiliary absorption	[A]	0.5
Power supply:	3~400V, 1N~230V - 50Hz	
Electric protection degree:	IP 40	
Noisiness *** min. - max.	[dB(A)]	69-72
Burner weight ****	[kg]	30.5

* Reference conditions: Environment temperature 20°C - Barometric pressure 1013 mbar - Altitude 0 meter (sea level).

** Minimal feeding-gas pressure to the gas train to get the maximum power of the burner, considering counter-pressure in combustion chamber of value 0 (zero).

*** Measured sonorous pressure in the laboratory combustion, with functional burner on beta boiler to 1 meter of distance (UNE EN ISO 3746) - Control method Class 3 - The tolerance on the measured sound pressure can be assumed equal to ± 1 [dB (A)].

**** For burner with long head adds 1 kg to the weight.

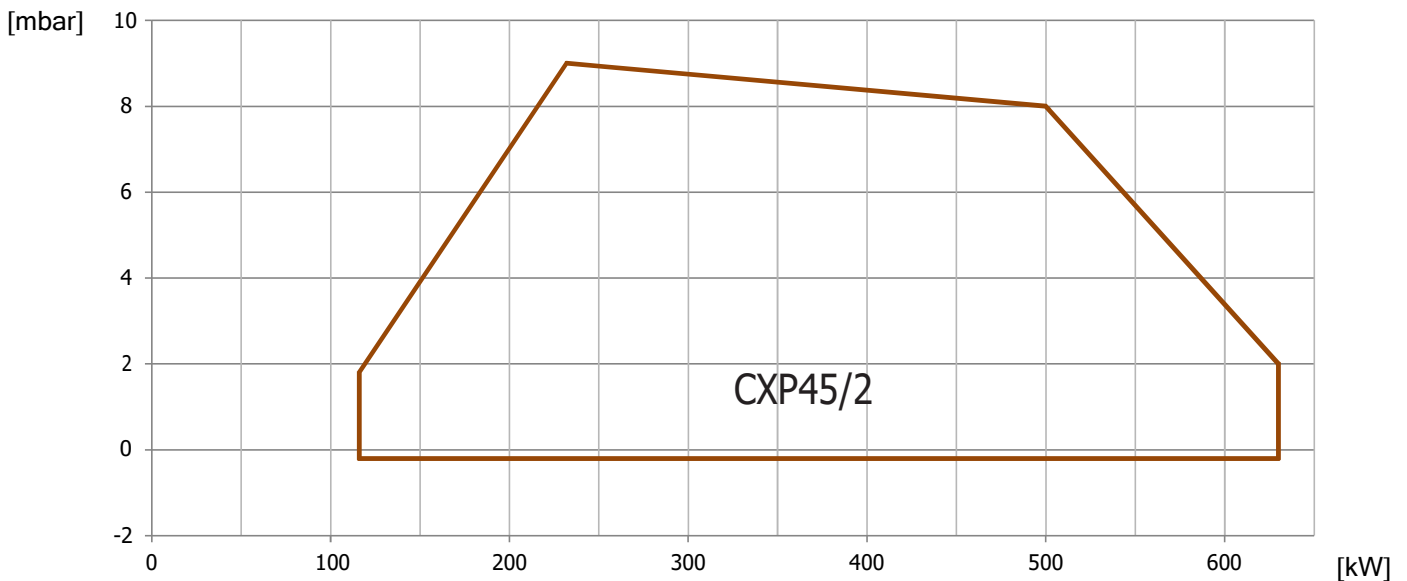

Fig. 2 X = Thermal power Y = Pression in the combustion chamber

The firing rates has been obtained based on test boilers in accordance with EN267 standards and are indicative of matching the burner to the boiler. For the correct operation of the burner, combustion chamber dimensions must be in accordance with current regulation. In case of non-compliance, contact the manufacturer.

DIMENSIONS [MM]

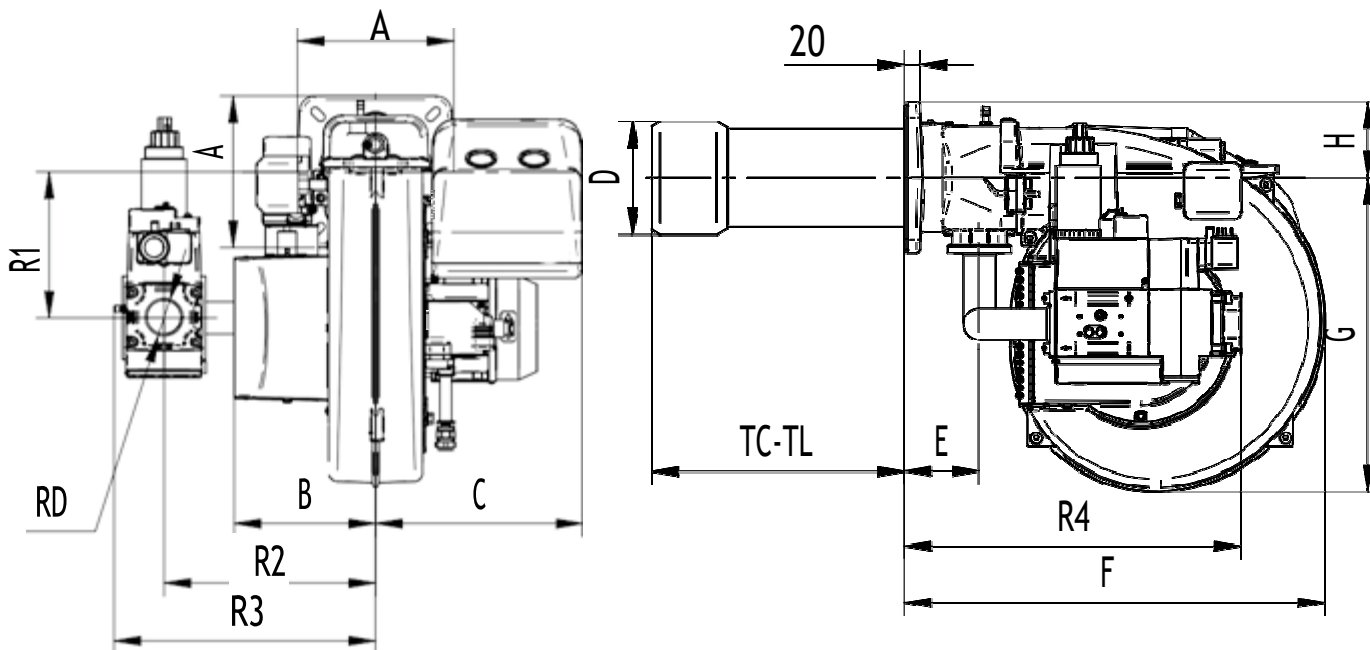

Fig. 3 Dimensions CXP45/2 MAX

MODEL	A	B	C	D	E	F	G	H	R1	R2	R3	R4	RD	TC	TL
CXP-45/2 MAX - D1"-S	200	188	276	150	99	558	416	100	193	280	338	431	Rp 1	250	335
CXP-45/2 MAX - D1"1/4-S	200	188	276	150	99	558	416	100	193	280	338	431	Rp 1 1/4	250	335
CXP-45/2 MAX - D1"1/2-S	200	188	276	150	99	558	416	100	193	280	346	446	Rp 1 1/2	250	335

BOILER PLATE

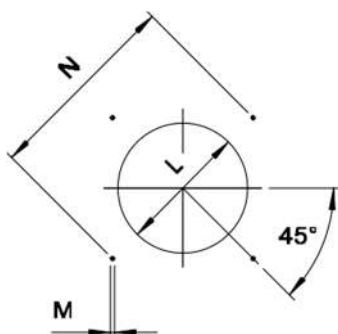

Fig. 4 Boiler plate

* Suggested dimension of connection between burner and generator.

MODEL	mm	L min	L *	L max	M	N min	N *	N max
CXP 45/2 MAX	mm	160	160	180	M10	205	205	226

FLAME TUBE LENGTH

Flame tube length must be selected based on the specifications supplied by boiler manufacturer and, in any case, it must be greater than the thickness of the boiler door included its insulation.

In case of boilers with flame inversion or front flue combustion chambers, it is necessary to insulate the area between the flame tube and front door with refractory material. This protection material must not impede flame tube extraction.

MODEL	mm	TC	TL **
CXP 45/2 MAX	mm	250	335

** For different flame lengths, please contact our Technical-Sales Department.

BURNER SIGNS DESCRIPTION

In the picture below there are indicated all the burner signs:

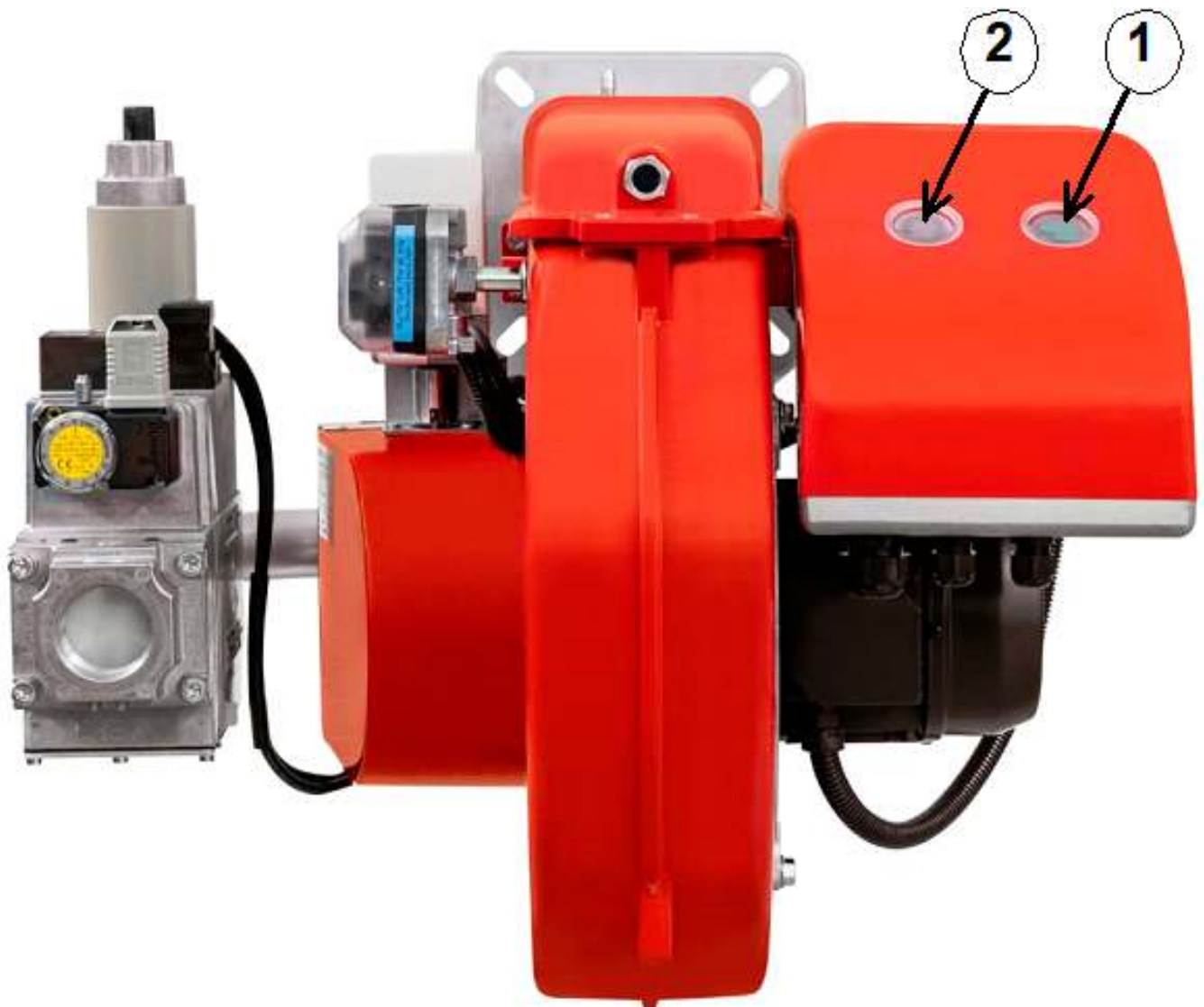



Fig. 5 Burner signs description

LEGEND

- 1) ON/OFF button
- 2) Reset from lockout button + status lamp

 The multicolor signal lamp in the lockout reset button (pos.2) is the key indicating element for visual diagnostics and interface diagnostics.
In normal operation, the different operating states are indicated in the form of color codes; please refer to electrical device handbook supplied with the present instructions.

 After a non-alterable lockout, the red signal lamp in the lockout reset button (pos.2) lights up.
By pressing the lockout reset button (pos.2) for more than 3 seconds, the visual diagnostics of the cause of fault can be activated; please refer to electrical device handbook supplied with the present instructions.

For close the diagnostics mode and for switch on the burner again, it is necessary to reset the burner control.
Press the lockout reset button (pos.2) for about 1 second (<3 seconds).

 After a non-alterable lockout, the red signal lamp in the lockout reset button (pos.2) lights up.
For reset the control box press the lockout reset button (pos.2) for about 1 second (<3 seconds).

PRODUCT SPECIFICATION

SHORT DESCRIPTION

Gas burners two stages.

DETAILED SPECIFICATION

Gas burner two stages composed by:

- Aluminum body;
- Fan at high pressurization with reverse blades;
- Combustion head with adjustment at high performance and elevated flame stability equipped with inox steel blast tube and steel flame disc;
- Flange and insulating gasket for fixing at boiler;
- Three-phase power supply;
- Safety air pressure switch to stop the burner in lock-out in case of failed or anomalous fan operation;
- Gas train with safety valve class A, adjustment two stages valve class A;
- Optional valve proving system;
- Ionization probe for flame detection;
- IP 40 electric protection level;
- Servomotor for air shutter and for the consent of the 2nd stage gas valve;
- Moving shutter with total closure when idle in order to reduce at the least energy losses related to boiler cooling down;
- Easy extraction of combustion head without gets off the burners by boiler.

CONFORMING TO:

- CE rules;
- 2014/30/UE Directive E.M.C. ;
- 2014/35/UE Directive L.V.;
- 2006/42/CE - 2006/42/EG - 2006/42/EC Directive M.D. ;
- GAS 2016/426/UE Regulation;
- Reference rules: EN 676 (gas) - EN 746-2 (industrial thermoprocessing equipment).

STANDARD EQUIPMENT

- Isomart gasket;
- Flange with insulating gasket;
- Burner nameplate;
- Warranty;
- Instruction handbook for installation, use and maintenance.

OPTIONAL

- Noise protection;
- Antivibration couplings;
- Handle gas taps.