

DATOS TÉCNICOS

MODELO		CX8/M	CX15/M	CX20/M
Potencia térmica mín 1ºllama/mín 2ºllama-máx 2ºllama *	[Mcal/h]	15/35-80	30/60-150	40/100-200
Potencia térmica mín 1ºllama/mín 2ºllama-máx 2ºllama *	[kW]	17/41-93	35/70-174	46/116-232
Caudal G20 (METANO) mín 1ºllama/mín 2ºllama-máx 2ºllama *	[Nm ³ /h]	1.7/4.1-9.4	3.5/7-17.4	4.6/11.6-23.2
Caudal G31 (GPL) mín 1ºllama/mín 2ºllama-máx 2ºllama *	[Nm ³ /h]	0.7/1.6-3.6	1.3/2.7-6.5	1.8/4.5-9
Combustible: GAS NATURAL (segunda familia) - GPL (tercera familia)				
Categoría combustible : I _{2R} , I _{2H} , I _{2L} , I _{2E} , I _{2E+} , I _{2Er} , I _{2ELL} , I _{2E(R)B} / I _{3B/P} , I ₃₊ , I _{3P} , I _{3B} , I _{3R}				
Funcionamiento a servicio intermitente (mín. 1 parada cada 24 horas), 2 llamas progresivo o modulante				
Condiciones entorno permitido en ejercicio / almacenaje : -15... +40°C / -20... +70°C, humedad rel. máx. 80%				
Máx temperatura aire comburente	[°C]	60	60	60
Presión mínima rampa gas D3/4"-S METANO/GPL **	[mbar]	18/24	-	-
Presión mínima rampa gas D1"-S METANO/GPL **	[mbar]	-	14/31	14/21
Presión máxima entrada válvulas (Pe.max)	[mbar]	360	360	360
Potencia eléctrica nominal	[W]	130	200	226
Motor ventilador	[W]	75	110	200
Absorción nominales	[A]	0.6	0.9	1.1
Alimentación eléctrica:		1/N~230V-50Hz	1/N~230V-50Hz	1/N~230V-50Hz
Grado de protección eléctrica:		IP40	IP40	IP40
Rumorosidad *** mín-máx	[dBA]	61-62	66-71	66-71
Peso quemador ****	[kg]	11	15	17

* Condiciones de referencia: Temperatura entorno 20°C - Presión barométricos 1013 mbar - Altitud 0 m s.n.m.

** Presión mínima de alimentación del gas a la rampa para conseguir la máxima potencia del quemador considerando la contra presión en cámara de combustión a valor 0 (cero).

*** Presión sonora medida en laboratorio combustión, con quemador en función sobre caldera de prueba a 1m de distancia.

**** Por quemador con capó de acero (F) añadir kg 3 al peso.

CAMPO DE TRABAJO (EN676) : Potencia térmica - Presión en cámara de combustión

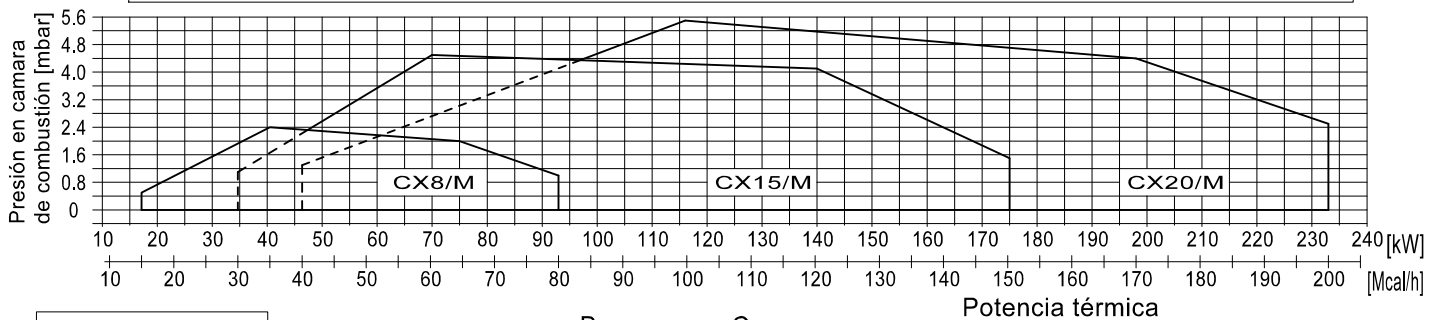

MEDIDAS [mm]

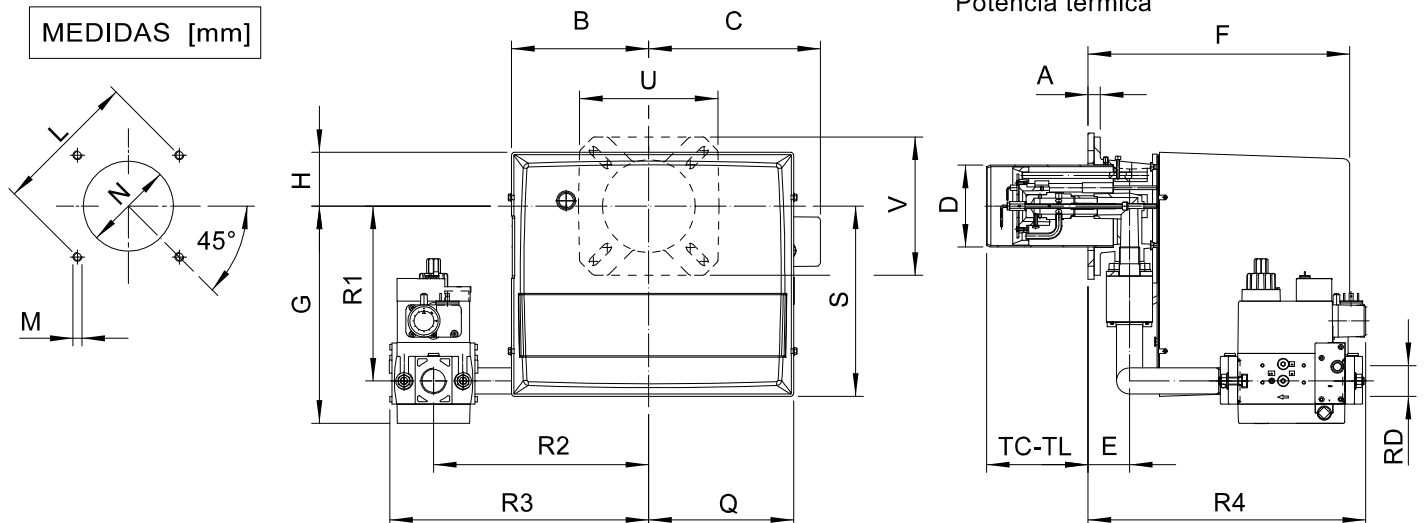

* : Dimensión aconsejada de enlace entre quemador y generador.

MODELO	A	B	C	D	E	F	G	H	L			M	N			Q	S	U	V	TC	TL	R1	R2	R3	R4	RD	Peso rampa gas
									min	*	max		min	*	max												
CX8/M-D3/4"-S	15	162	200	90	43	305	215	65	130	150	170	M8	100	110	130	170	211	150	150	90	150	178	220	262	346	Rp 3/4	2 kg
CX15/M-D1"-S	16	185	224	108	54	340	282	70	150	170	170	M8	120	130	140	190	248	200	160	130	250	228	280	338	360	Rp 1	6 kg
CX20/M-D1"-S	20	185	224	125	78	368	288	70	170	205	226	M10	130	140	160	190	248	200	200	160	280	233	280	338	385	Rp 1	6 kg

SERIE CX

2 LLAMAS Y PROGRESIVOS & MODULANTES DESDE 23 HASTA 349 kW
2 ALLURES ET PROGRESSIVES & MODULANTES DE 23 JUSQU'À 349 kW



2 LLAMAS 2 ALLURES	PROGRESIVOS & MODULANTES PROGRESSIVES & MODULANTES	kcal/h		kW		1F
		min	max	min	max	
CX 5/2		20.000	50.000	23,2	58	
CX 8/2	CX 8/M	35.000	80.000	40,6	93	
CX 15/2 *	CX 15/M *	60.000	150.000	70	174	
CX 20/2 *	CX 20/M *	100.000	200.000	116	232	
CX 30/2 *	CX 30/M *	130.000	300.000	151	349	



* Disponible también en versión Bajo NOx /
Egalement disponible en version Bas NOx

CURVA DE FUNCIONAMIENTO / MEDIDAS (mm)

COURBES ET PERFORMANCES / DIMENSIONS (mm)

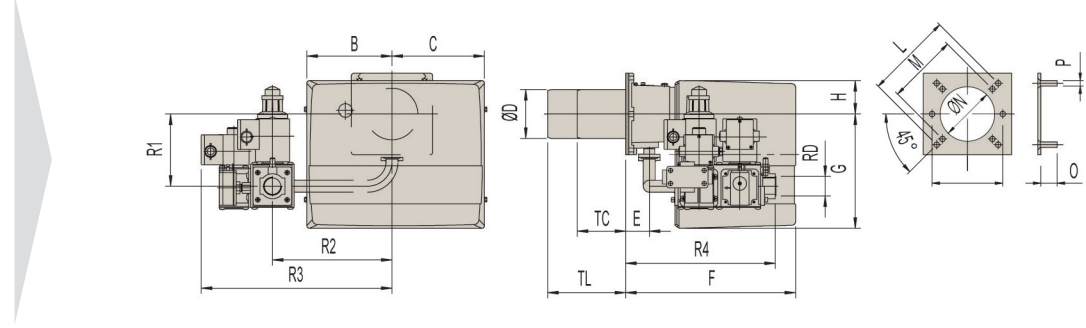

Presión en la cámara de combustión [mbar] /
Pression dans la chambre de combustion [mbar]

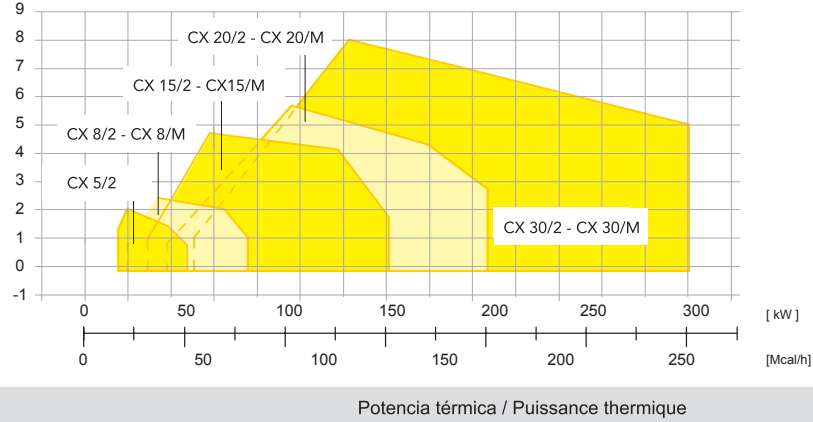

Potencia térmica / Puissance thermique

MODELO MODÈLE	B	C	D	E	F	G	H	I	L	M	N	O	P	Q	S	U	TC	TL	R1	R2	R3	R4	RD
CX 5/2 - D 1/2"	157	170	90	45	313	210	65	130	160	130	100	30	M8	R15	150	150	85	145	133	200	275	258	1/2
CX 8/2 - D 3/4" FS25	157	170	90	45	313	210	65	130	160	130	100	30	M8	R15	150	150	85	145	138	220	351	275	1
CX 15/2 - D 1"	185	195	108	52	340	248	70	160	170	150	120	30	M8	R15	190	190	130	250	168	280	337	361	1
CX 20/2 - D 1"	185	195	125	78	368	248	70	-	226	170	135	40	M10	R30	220	220	160	280	173	280	337	385	1
CX 30/2 - D 1"	207	213	138	98	462	310	90	-	226	205	148	40	M10	R30	220	220	250	335	255	305	362	403	1"
CX 30/2 - CTD1"	207	213	138	98	462	310	90	-	226	205	148	40	M10	R30	220	220	250	335	255	305	480	403	1"
CX 30/2 - D 1" 1/4	207	213	138	98	462	310	90	-	226	205	148	40	M10	R30	220	220	250	335	255	305	362	450	1"1/4
CX 30/2 - CT D 1" 1/4	207	213	138	98	462	310	90	-	226	205	148	40	M10	R30	220	220	250	335	255	305	480	450	1"1/4
CX 8/M - D 3/4"	157	200	90	45	305	211	65	130	160	130	100	30	M8	R15	150	150	89	149	178	220	262	328	3/4"
CX 15/M - D 1"	185	224	108	54	340	248	70	160	170	150	120	30	M8	R15	190	190	130	250	228	280	338	360	1"
CX 20/M - D 1"	185	224	125	78	368	248	70	-	226	170	135	40	M10	R30	220	220	160	280	233	280	338	385	1"
CX 30/M - D 1"	207	213	138	98	462	310	165	-	226	205	148	40	M10	R30	220	220	250	335	160	305	395	508	1"
CX 30/M - D 1" 1/4	207	213	138	98	462	310	165	-	226	205	148	40	M10	R30	220	220	250	335	160	305	395	508	1"1/4

